



+ WEB Bonus!

Colorful cowl neck sweater



An oversized cowl and roomy dropped shoulders compose a cozy sweater you will want to wear every day. The fancy sequin-enhanced yarn makes this sweater perfect for every occasion. Yarn: Bamboo Cotton, Soxie, Tribbles, and HD sequins by Great Adirondack Yarn Co.

Designed by **Brigitte Reydams**

Skill level: Intermediate

Sizes: Women's Medium

Finished measurements:
Bust: 38"
Length: 26"

Yarn weight: 5

Materials

- 2½ skeins Bamboo Cotton by Great Adirondack Yarn Co, 51% cotton, 49% bamboo, (495 yds/227g) in color Wildflowers (A)
- 3 skeins Soxie by Great Adirondack Yarn Co, 100% merino superwash wool, (360 yds/100g) in color Wildflowers (B)
- 3 skeins Tribbles by Great Adirondack Yarn Co, 80% rayon, 20% cotton, (60 yds/50g) in color Aqua Green (C)
- 3 skeins HD Sequins by Great Adirondack Yarn Co, 60% cotton, 40% PVC, (75 yds) in color Wildflowers (D)
- U.S. size 10 (6mm) needles, or size required for gauge
- Stitch holders
- Stitch markers
- Yarn needle

Gauge

15 sts and 20 rows = 4" (10cm) in St st with 1 strand each of A and B held tog

Sweater

Back-Lower edge

With 2 strands of B and 1 strand of D held tog, cast on 16 sts.

Rows 1 and 2: With 2 strands of B and 1 strand of D, knit.

Rows 3 and 4: With C, knit.

Rep rows 1–4 until piece measures 18½", then work rows 1 and 2 once more. Bind off.

Body

Turn piece so that long side edge is facing up. With 1 strand each of A and B held tog, pick up and knit 72 sts along edge. Work even in St st for 2", ending with a WS row.

Shape sleeves

Cont in St st, inc 1 st each end of row every other row 9 times; 90 sts. Then inc 1 st each end of row every row 26 times; 142 sts. Work even until piece measures 25" from beg.

Shoulder edge

Change to C. Knit 2 rows. Change to 2 strands of B and 1 strand of D held tog. Knit 2 rows. Change to C. Knit 2 rows. Bind off.

Front-Lower edge

Work as for back.

Body

Work as for back until piece measures 20" from beg, ending with a WS row; 142 sts.

Shape neck

Next row (RS): K71, place rem 71 sts on holder, turn.

Next row: Bind off 3 sts at neck edge, purl to end; 68 sts. Cont in St st, dec 1 st at neck edge every row 4 times, then every other row 4 times; 60 sts. Finish as for back.

Place 71 held neck sts on needles and work as for opposite side, reversing shaping.

Finishing

Sew shoulder and upper sleeve seams.

Sleeve cuffs

With A and B held tog, pick up and knit 48 sts along end of sleeve. Work in St st for 5". Bind off.

Lower edge

Work as for back until piece measures same as width of sleeve cuff. Bind off. Sew in place.

Sew side and lower sleeve seams.

Cowl neck

With 2 strands of B and 1 strand of D held tog, cast on 24 sts. Work as for lower edge of back until piece measures same as neck opening. Bind off. Sew in place.

Weave in ends. ▣

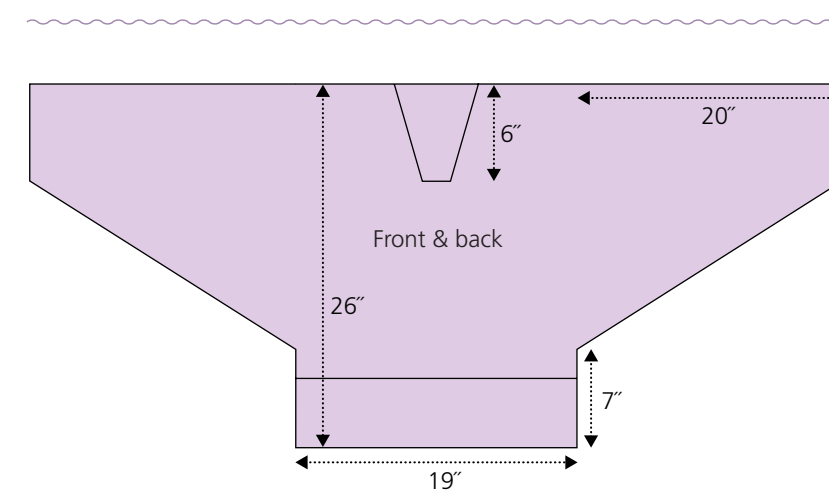

Colorful cowlneck sweater